

Reversible motor driver

BA6286 / BA6286N

The BA6286 and BA6286N are reversible-motor drivers with a maximum output current of 1.0A. Two logic inputs allow four output modes: forward, reverse, stop (idling), and brake. A built-in power saving circuit suppresses current consumption when the motor is in stop mode.

●Applications

VCRs and audio equipment in general

●Features

- 1) Logic and power sections have separate ground pins; this allows the IC to drive speed-variable, reversible motors by connecting an electronic governor circuit.
- 2) Built-in power saving circuit suppresses the stop mode current dissipation.
- 3) Output voltage can be set arbitrarily with the V_{REF} pin.
- 4) Interfaces with TTL devices.
- 5) Built-in thermal shutdown circuit.

●Absolute maximum ratings ($T_a = 25^\circ\text{C}$)

Parameter		Symbol	Limits	Unit
Power supply voltage		V_{CC}	18	V
Power dissipation	BA6286	P_d	2000*1	mW
	BA6286N		1050*2	
Operating temperature		T_{opr}	$-20 \sim +75$	$^\circ\text{C}$
Storage temperature		T_{stg}	$-55 \sim +150$	$^\circ\text{C}$
Output current		I_{out}	1000*3	mA

*1 Reduced by 16.0 mW for each increase in T_a of 1°C over 25°C .

*2 Reduced by 8.4 mW for each increase in T_a of 1°C over 25°C .

*3 Should not exceed p_d -or ASO value.

●Recommended operating conditions ($T_a = 25^\circ\text{C}$)

Parameter	Symbol	Min.	Typ.	Max.	Unit
Operating power supply voltage	V_{CC}	4.5	—	15	V
	V_M	4.5	—	15	V
	V_{REF}	4.5	—	15	V

● Block diagram

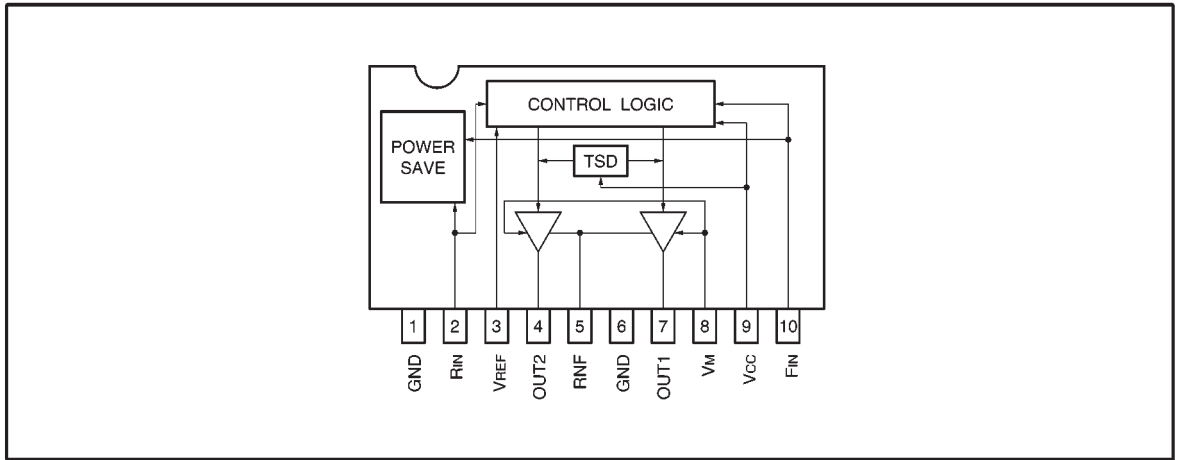

● Pin descriptions

Pin No.	Pin name	Function
1	GND	GND
2	R _{IN}	Logic input
3	V _{REF}	HIGH level output voltage setting
4	OUT2	Motor output
5	R _{NF}	Output section ground pin; resistor connection for detecting output current
6	GND	GND
7	OUT1	Motor output
8	V _M	Motor power supply
9	V _{CC}	Power supply
10	F _{IN}	Logic input

● Input / output circuits

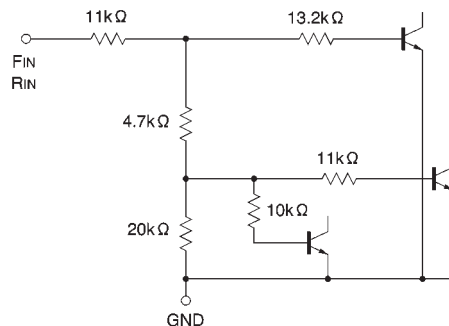
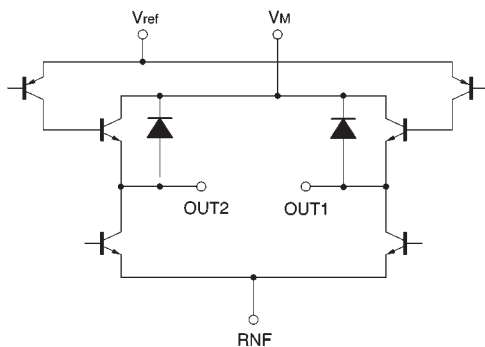

●Electrical characteristics (unless otherwise noted, $T_a = 25^\circ\text{C}$, $V_{CC} = 9\text{V}$, $V_M = 9\text{V}$, $V_{REF} = 9\text{V}$)

Parameter	Symbol	Min.	Typ.	Max.	Unit	Conditions	Measurement circuit
Supply current 1	I_{CC1}	12	24	36	mA	Forward or reverse mode	Fig.1
Supply current 2	I_{CC2}	29	48	67	mA	Brake mode	
Standby supply current	I_{ST}	—	—	15	μA	Standby mode	
V_{REF} pin sink current	I_{REF}	6	12	18	mA	Forward or reverse mode $I_O = 200\text{mA}$	Fig.2
Input high level voltage	V_{IH}	2.0	—	—	V		
Input low level voltage	V_{IL}	—	—	0.8	V		
Input high level current	I_{IH}	45	90	135	μA	$V_{IN} = 2.0\text{V}$	Fig.3
Output saturation voltage	V_{CE}	—	1.0	1.5	V	$I_O = 200\text{mA}$ Sum of output transistor high- and low-side voltages	

●Measurement circuit

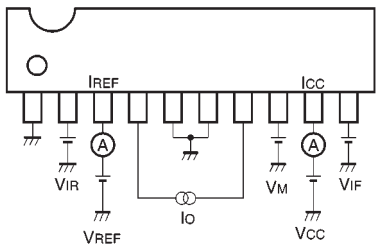

* Refer to the truth table for output mode. The supply current is represented by the I_{CC} -value, and the V_{REF} sink current is represented by the I_{REF} -value. The direction of the I_O current is from the HIGH level to the LOW level output pin.

Fig.1

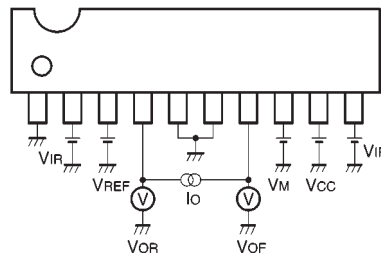

V_{CE} is the sum of the high- and low-side output transistor C-E voltages. The direction of the I_O current is from the HIGH level to the LOW level output pin.

Fig.3

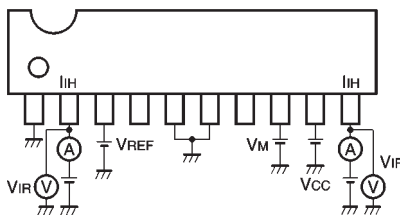

* Refer to the truth table for output mode. HIGH and LOW level input voltages correspond to the readings of V_{IF} voltmeters, respectively. The HIGH level input current is represented by the I_{IH} ammeter reading when $V_{IN} = 2\text{V}$.

Fig.2

● Circuit operation

(1) Input section

The four output modes are controlled by two logic inputs. Current flows from OUT1 to OUT2 when F_{IN} is HIGH and R_{IN} is LOW, and from OUT2 to OUT1 when R_{IN} is HIGH and F_{IN} is LOW (refer to the truth table). The input circuit can be operated by a logic circuit with a current capacity of 120 ~ 170 μ A.

(2) Output section

Current flows from OUT1 to OUT2 during forward rotation, and from OUT2 to OUT1 during reverse rotation. The output voltages V_{OH} and V_{OL} are given by :

$$V_{OH} [V] = V_{REF} - V_{CE(sat)}(PNP) - V_{BE(NPN)}$$

$$V_{OL} [V] = V_{CE(sat)}(NPN)$$

V_{CE} and V_{BE} are functions of the output current (see electrical characteristic curves). The output current can be set with the V_{REF} pin.

(3) Power saving circuit

All circuits are turned off when the F_{IN} and R_{IN} input pins are both put to LOW level. This circuit saves power during standby mode by leaving the outputs OPEN.

(4) Thermal shutdown circuit

When the thermal shutdown circuit is activated at the chip temperature of about 175°C (typical), the outputs are left OPEN. The temperature difference between the activation and deactivation settings is about 15°C. When the thermal shutdown circuit is deactivated, the outputs revert to the status determined by input mode.

● Input / output truth table

FIN	RIN	OUT2	OUT1	MODE
H	L	L	H	Forward
L	H	H	L	Reverse
H	H	L	L	Brake
L	L	OPEN	OPEN	Standby

● Application example

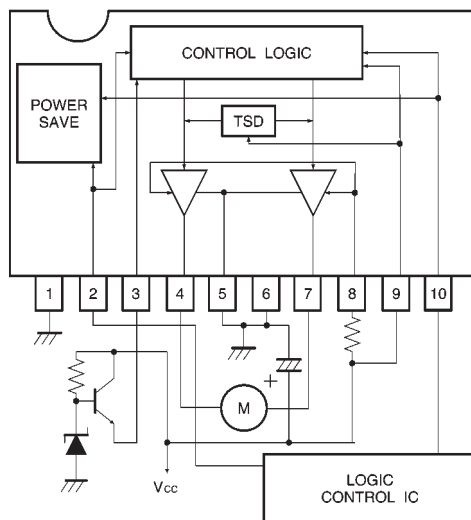

Fig.4

● Operation notes

(1) The quality of these products have been carefully checked; however, use of the products with applied voltages, operating temperatures, or other parameters that exceed the absolute maximum rating given may result in the damage of the IC and the product it is used in. If the IC is damaged, the short mode and open modes cannot be specified, so if the IC is to be used in applications where parameters may exceed the absolute maximum ratings, then be sure to incorporate fuses, or other physical safety measures.

(2) GND potential

The potential for pin 1 must be kept lower than the potentials of the other pins regardless of the circumstances.

(3) Input pins

Voltage should never be applied to the input pins when the V_{CC} voltage is not applied to the IC. Similarly, when V_{CC} is applied, the voltage on each input pin should be less than V_{CC} and within the guaranteed range for the electrical characteristics.

(4) Back-rush voltage

Depending on the ambient conditions, environment, or motor characteristics, the back-rush voltage may fluctuate. Be sure to confirm that the back-rush voltage will not adversely affect the operation of the IC.

(5) Large current line

Large currents are carried by the motor power supply and motor ground for these ICs.

Therefore, the layout of the pattern of the PC board and the constants of certain parameters for external components, such as the capacitor between the power supply and ground, may cause this large output current to flow back to the input pins, resulting in output oscillation or other malfunctions. To prevent this, make sure that the PC board layout and external circuit constants cause no problems with the characteristics of these ICs.

(6) Power dissipation

The power dissipation will fluctuate depending on the mounting conditions of the IC and the ambient environment. Make sure to carefully check the thermal design of the application where these ICs will be used.

(7) Power consumption

The power consumption by the IC varies widely with the power supply voltage and the output current. Give full consideration to the power dissipation rating and the thermal resistance data and transient thermal resistance data, to provide a thermal design so that none of the ratings for the IC are exceeded.

(8) ASO

Make sure that the output current and supply voltage do not exceed the ASO values.

(9) Precautions for input mode switching

To ensure reliability, it is recommended that the mode switching for the motor pass once through the open mode.

(10) In-rush current

There are no circuits built into these ICs that prevent in-rush currents. Therefore, it is recommended to place a current limiting resistor or other physical countermeasure.

(11) Factors regarding the thermal, power supply, and motor conditions

If the potential of the output pin sways greatly and goes below the potential of ground, the operation of the IC may malfunction or be adversely affected. In such a case, place a diode between the output and ground, or other measure, to prevent this.

(12) HIGH level output voltage setting pin

Ensure that the voltage applied to V_{REF} (pin 3) does not exceed the voltage on the motor power supply pin (pin 8) or the V_{CC} pin.

(13) The input pins (pins 2 and 10) have temperature-dependent characteristics. Take the temperature effect into consideration when using the IC.

(14) To eliminate motor noise, connect a capacitor between OUT1 (pin 7) and GND and between OUT2 (pin 4) and GND. Alternatively, connect a capacitor between OUT1 and OUT2, and also a diode between OUT1 and GND and between OUT2 and GND (see Fig. 5).

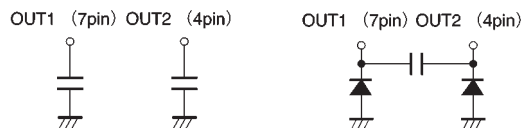

Fig.5

●Electrical characteristic curves

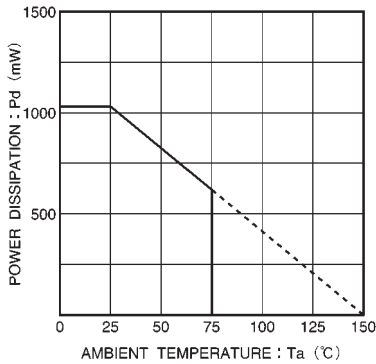

Fig.6 Temperature dependence of power dissipation curve (BA6286N)

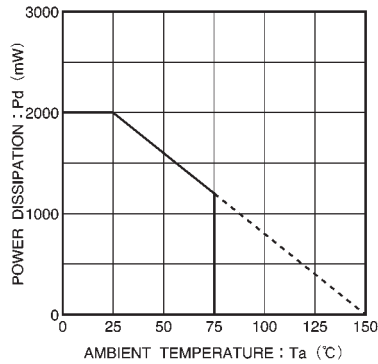

Fig.7. Temperature dependence of power dissipation curve (BA6286)

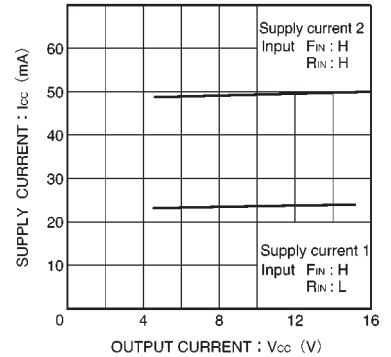

Fig.8 Supply current vs.output current

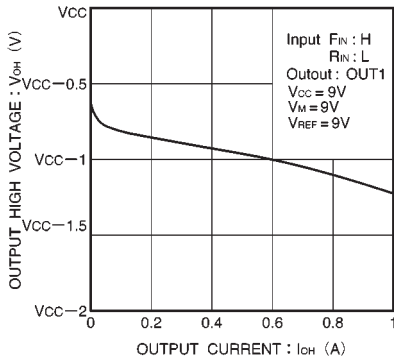

Fig.9 Output high level voltage vs. output current

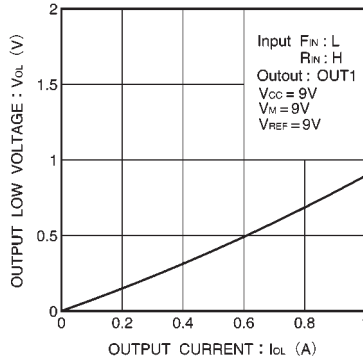

Fig.10 Output low level voltage vs. output current

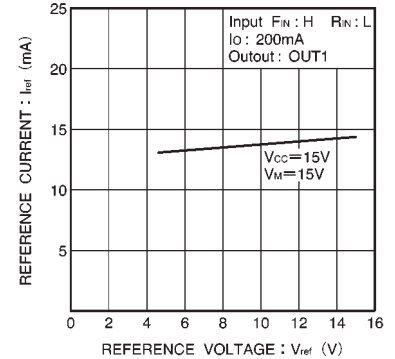

Fig.11 VREF pin input current vs. HIGH level reference voltage

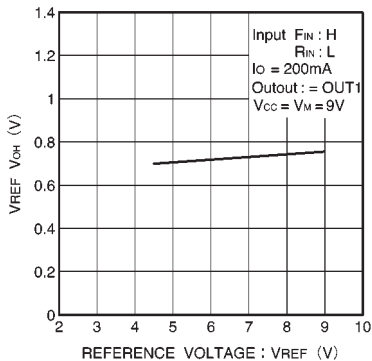

Fig.12 VREF-VOH voltage vs. VREF reference voltage

● External dimensions (Units: mm)

